

**PANIC / FIRE EXIT
CONCEALED
VERTICAL ROD DEVICES**

INSTALLATION INSTRUCTIONS

NARROW STILE DESIGN

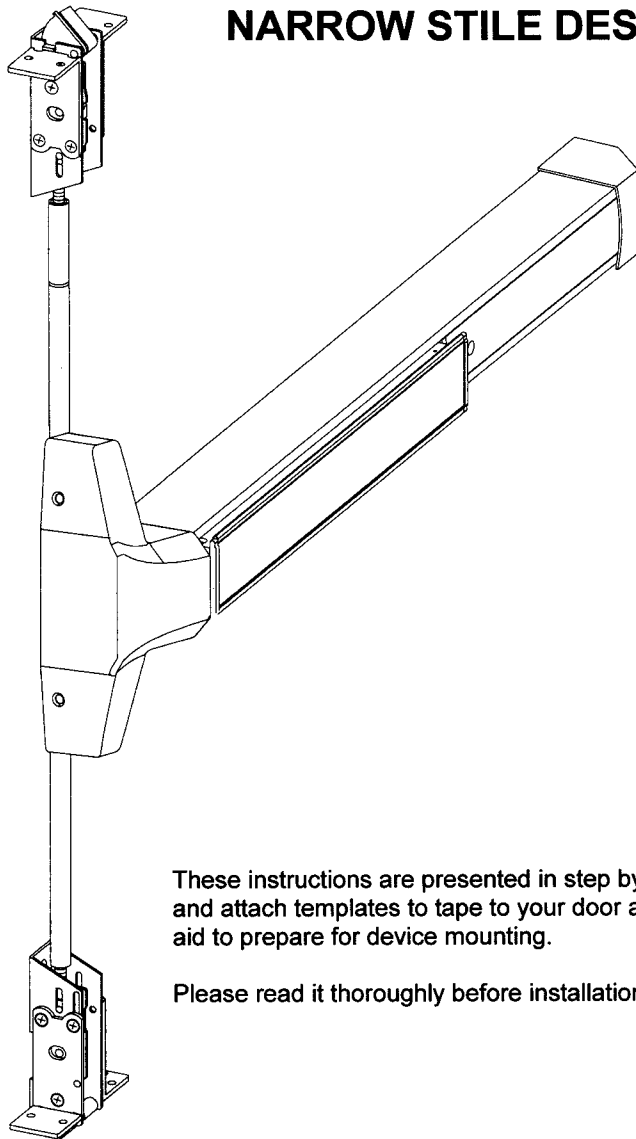

These instructions are presented in step by step sequence and attach templates to tape to your door and frame as an aid to prepare for device mounting.

Please read it thoroughly before installation.

Not to Scale

The use of non-clutching impact drivers to install this hardware will automatically void the warranty.

DESIGNATION OF PARTS

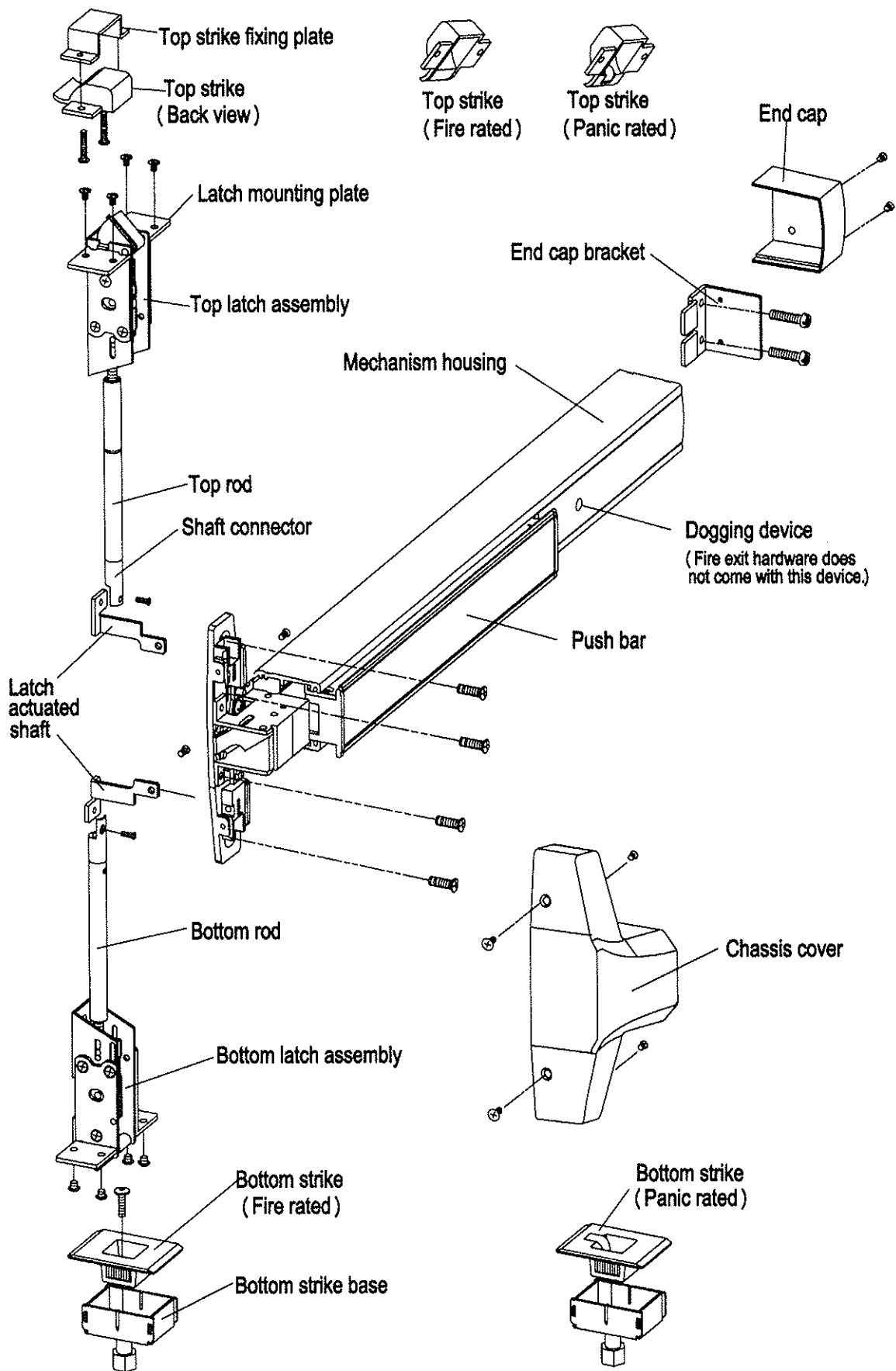

1 PREPARE DOOR

1. Mark center line of device by drawing a line across the door.
2. Mark a backset line and 4 thru holes for device chassis by template.
3. Prepare door cut-outs for the oblique lines indicated, using template.

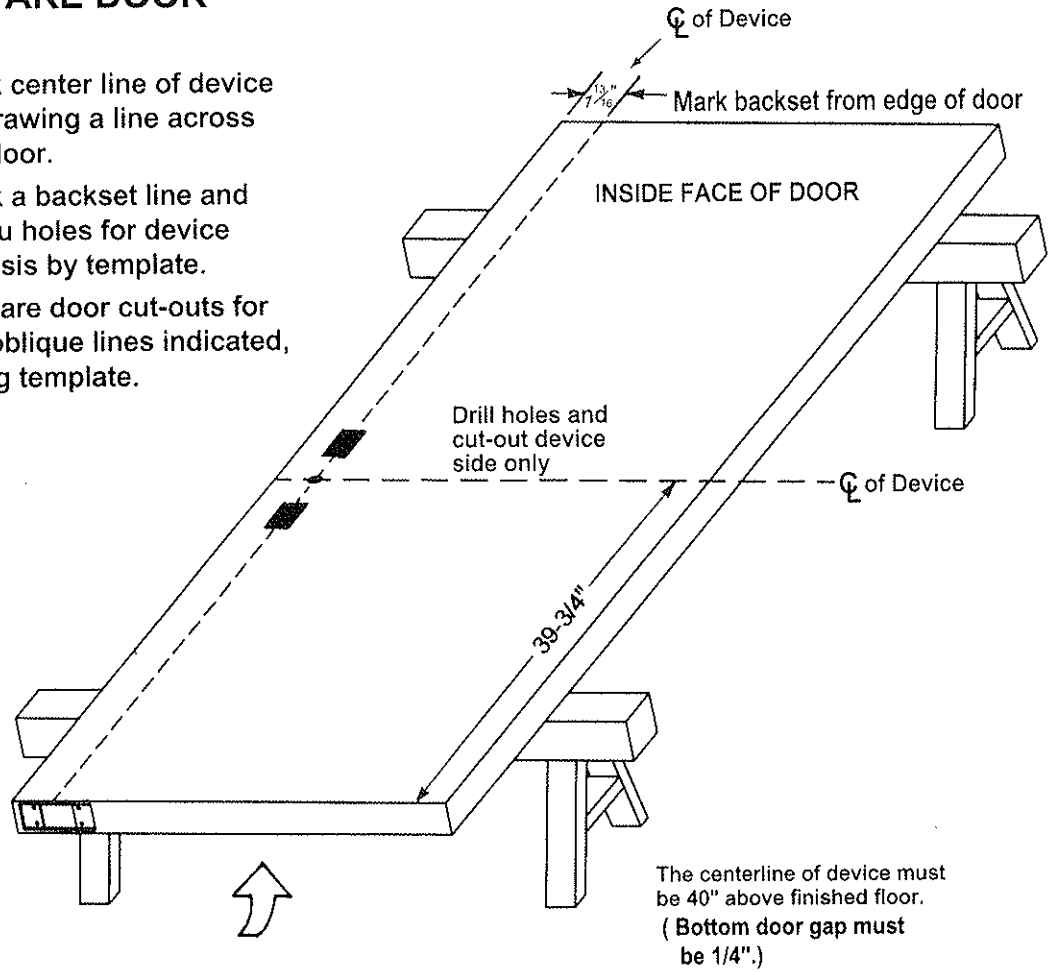

See Trim Installation Instructions for outside face of door preparation.

Figure 1-1

4. Cut out the top edge and bottom edge of the door, then weld two 5mm thick-mounting plates on both edges for Top Latch Assembly and Bottom Latch Assembly as per Figure 1-2.
5. Drill holes and tap #10-24 for the mounting plates on top and bottom of door.

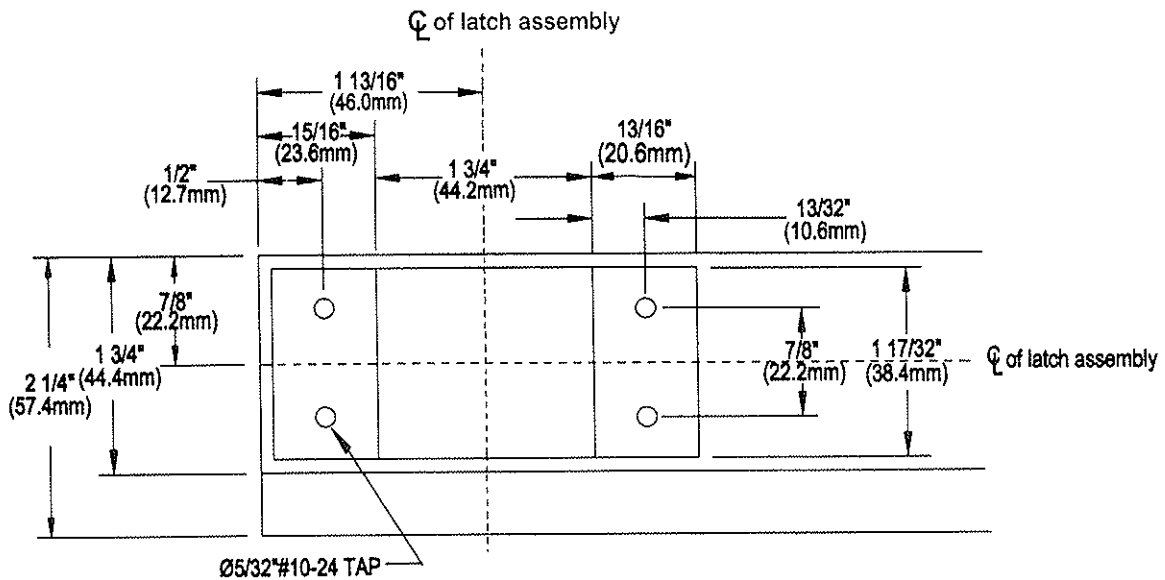

Figure 1-2

2 ASSEMBLE RODS AND LATCHES

1. Screw bottom rod into bottom latch assembly. (See Figure 2-1.)
2. Assemble top rod :
 - 2-1 Connect short top rod with long top rod by rod connector. (See Figure 2-2.)
 - 2-2 Measure and cut the length of top rod if it is too long.

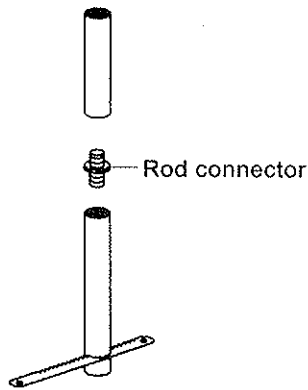

Figure 2-2

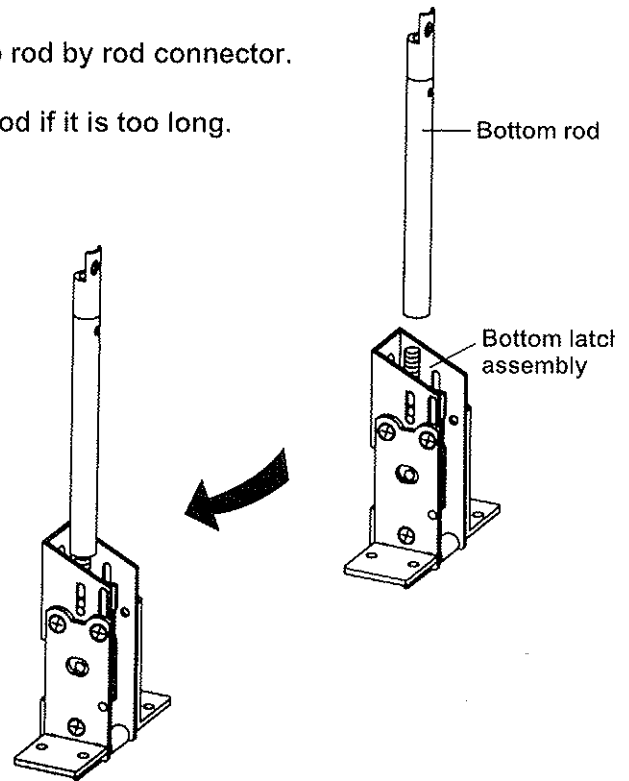

Figure 2-1

- 2-3 Insert shaft connector into the non-threaded end of top rod and fasten setting screw to it. (See Figure 2-3.)
3. Screw top rod assembly into top latch assembly. (See Figure 2-4.)

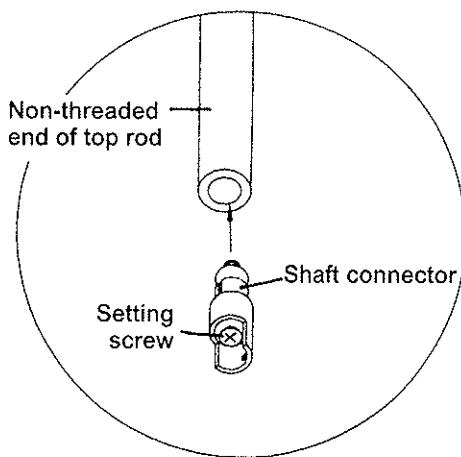

Figure 2-3

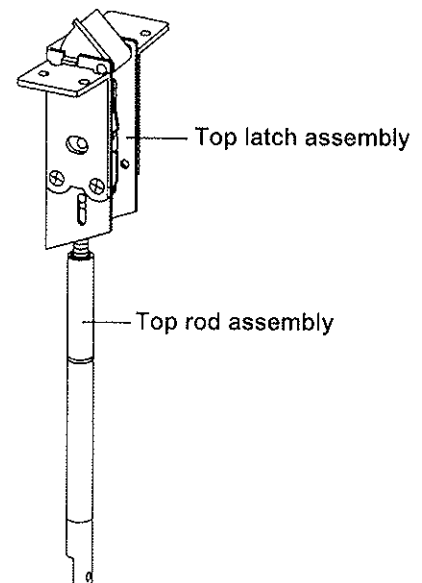

Figure 2-4

3 MOUNT LATCH ASSEMBLIES

1. Insert top latch assembly into top of the door and fasten top latch mounting brackets on the mounting plates at top of the door by supplied fixing screws. (See Figure 3-1.)
2. Insert bottom latch assembly into bottom of the door and fasten bottom latch mounting brackets on the mounting plates at bottom of the door. (See Figure 3-2.)

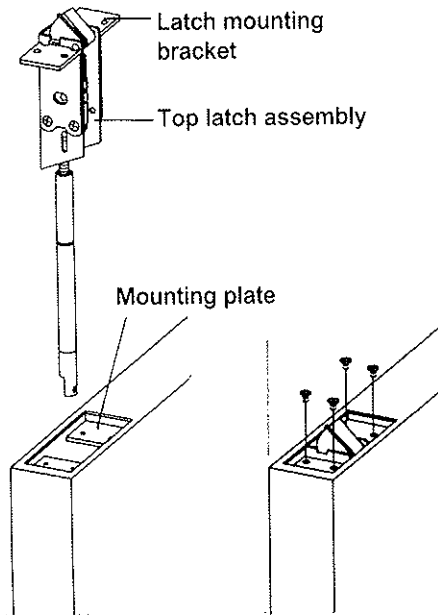

Figure 3-1

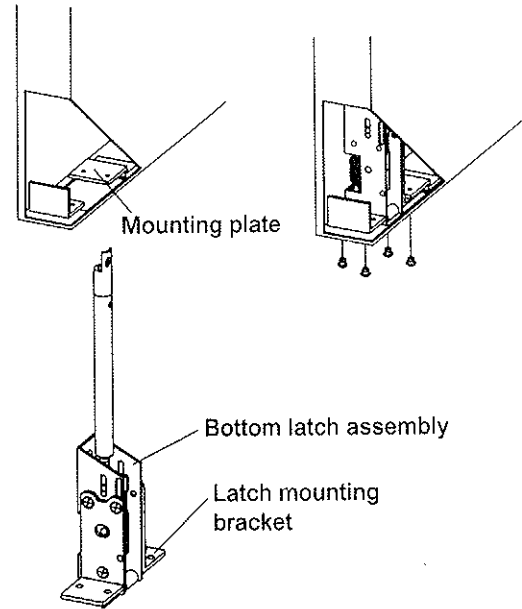

Figure 3-2

4 ADJUST VERTICAL RODS

1. Place the rod length locator into cut-out holes of the door, hook up the holes of both shaft connectors in turn using the small stud of locator as shown the figures below. When the shaft connector is raised up, check A and B holes whether these 2 holes match with a, b holes which have been cut out on the door. (See Figure 4-1.)
2. If A, B holes does not match in alignment with a, b holes that means the length of two vertical rods are incorrect and must be adjusted the length.

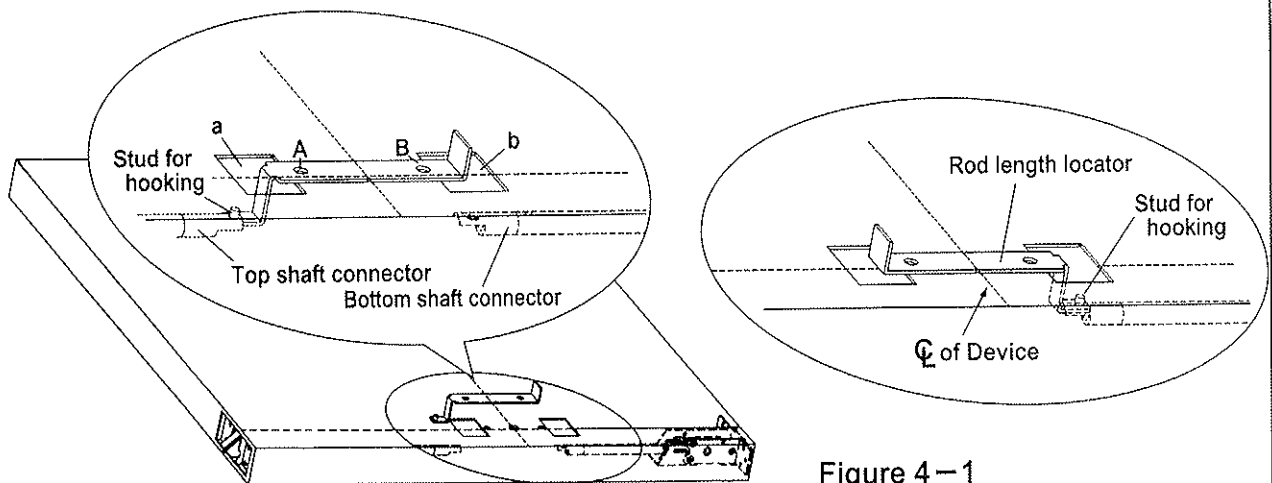

Figure 4-1

3. The adjustment procedure

Have thumb and first finger enter the cut-out holes to adjust the lengths of two vertical rods. (See Figure 4-2.)

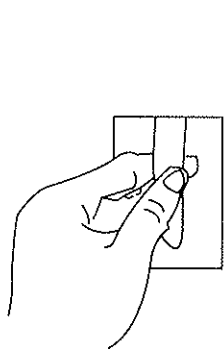

Figure 4-2

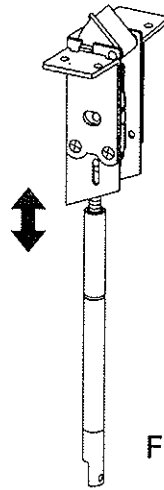

Figure 4-3

Turn the rod into latch assembly for shorten the overall length, or turn the rod out of the latch assembly for longer until the holes of both shaft connectors matched the holes of locator. (See Figure 4-3.)

5 INSTALL LATCH ACTUATOR SHAFTS

1. Connect Latch Actuated Shafts with Top Shaft Connector and Bottom Shaft Connector one each with supplied screws. (See Figure 5.)
2. Make sure Top Latch Actuated Shaft in parallel with Bottom Latch Actuated Shaft.

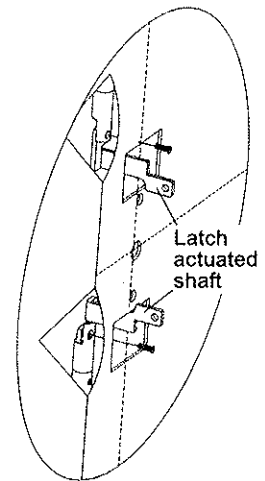

Figure 5

6 INSTALL DEVICE AND TRIM IF USING

1. Remove device chassis cover from the chassis assembly and end cap from end cap bracket.
2. Lay device in place on door and have top and bottom Latch Actuated Shafts insert into X, Y positions on chassis assembly then fasten with supplied screws. (See Figure 6-1.)

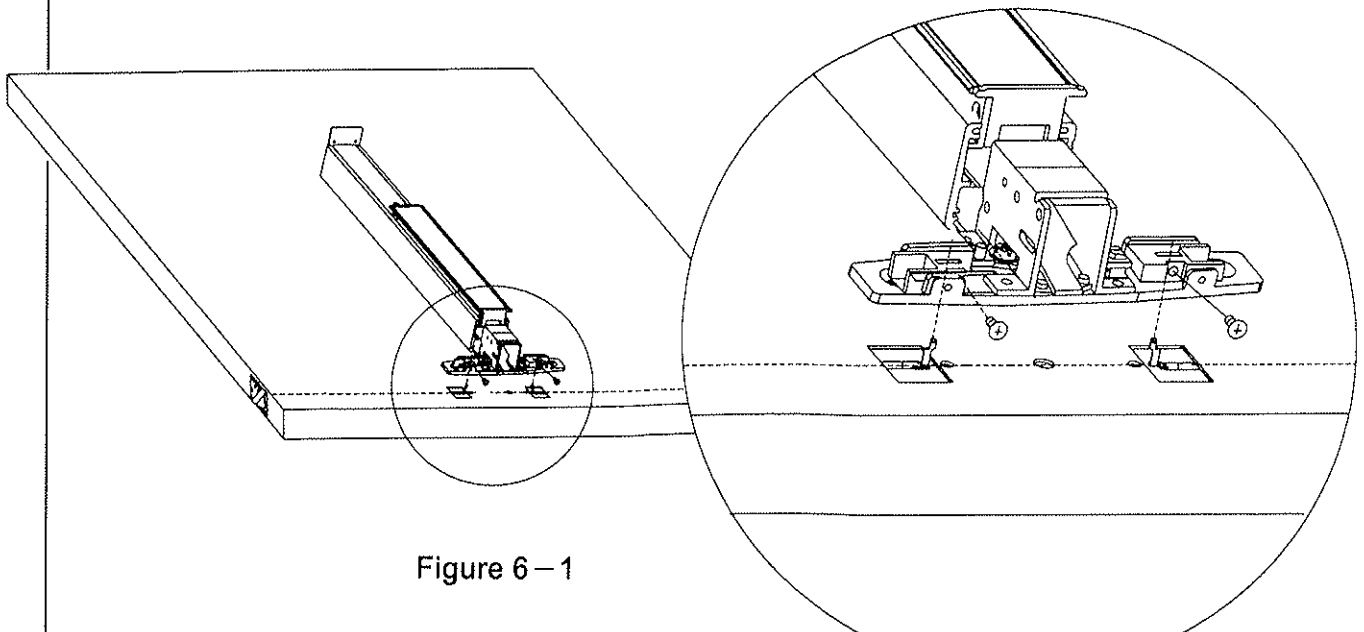

Figure 6-1

3. Cut the length if required:

- 3-1 The device length is precut for use on 36", and 48" wide door, no additional cutting is necessary. If narrow door installation is needed, cut device "A" portion to door width minus 2" to fit properly.
- 3-2 Remove device from door, measure and mark (with end cap removed) then cut it if required.

Note : Device must be cut plain and clean all burrs for proper end cap fit.

- 4. Mount device horizontally to the drilled position by securely supplied mounting screws, and bolt device chassis to trim or sex bolt (if using).
- 5. Install end cap bracket on device then screw to door. (See Figure 6-2.)

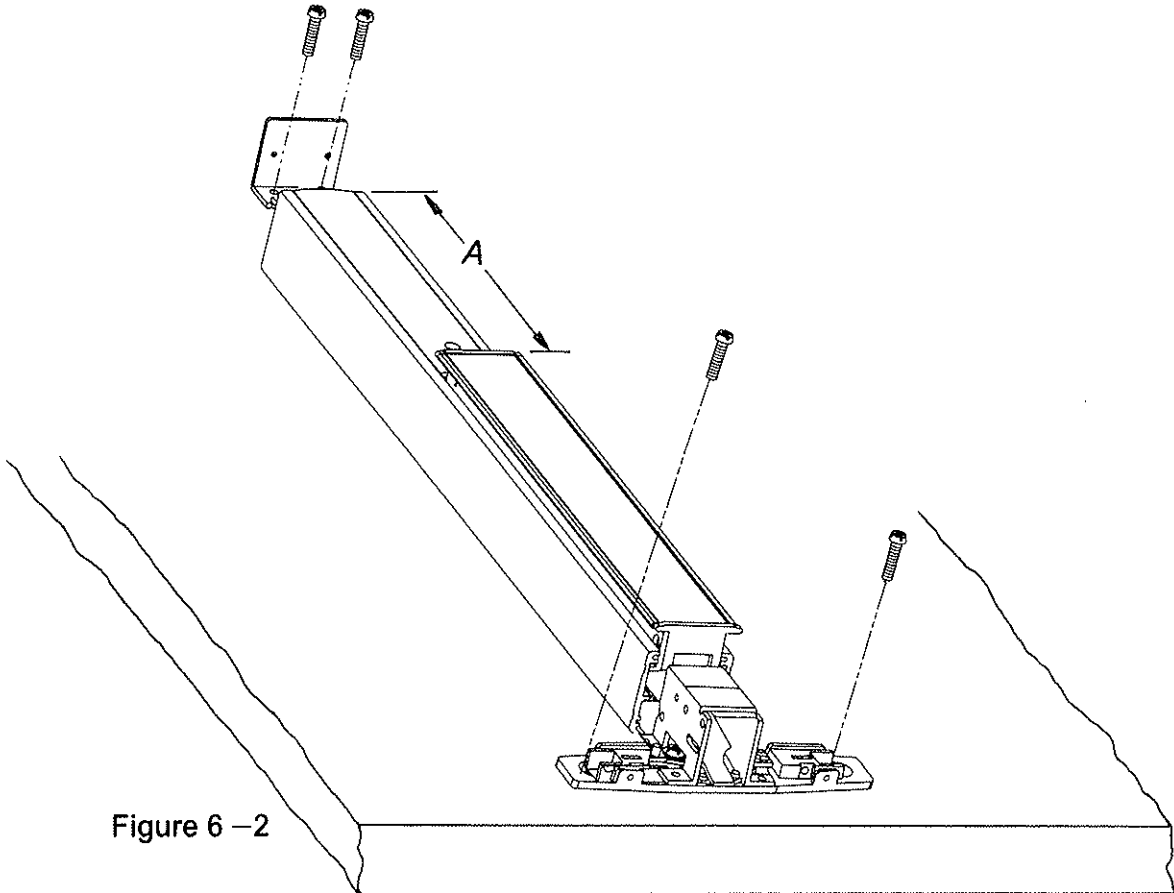

Figure 6 -2

7 TEST OPERATION AND HANG DOOR

- 1. Depress push bar, top latch bolt should be retracted as shown in Figure 7-1, and bottom latch bolt clears floor and bottom strike as shown in Figure 7-2.

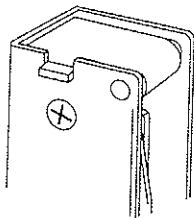

Figure 7 -1

BOTTOM
LATCH BOLT
(Clears floor
and strike)

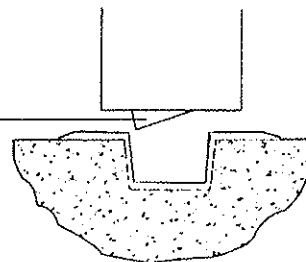

Figure 7-2

2. Release push bar, make sure both top latch bolt and bottom latch bolt should be fully extended.
3. Depress deadlock plate to check top latch bolt for deadlocking by thumb pressing, latch bolt should not be pushed in.
4. Check device operation by depressing and releasing push bar for several times to assure final correct installation.
5. Hang door (with device) and repeat operation check with outside lever.
6. Redo rod length adjustment if either top latch bolt is not held retracted or bottom latch bolt does not clear floor and bottom strike.

8 INSTALL TOP STRIKE

1. Prepare frame

- 1-1 Cut out a square hole on the frame for top strike as per Figure 8-1.
- 1-2 To weld two 3mm thick hold plates on the frame as per Figure 8-2.
- 1-3 Drill holes and tap #10-24 on the hold plates.

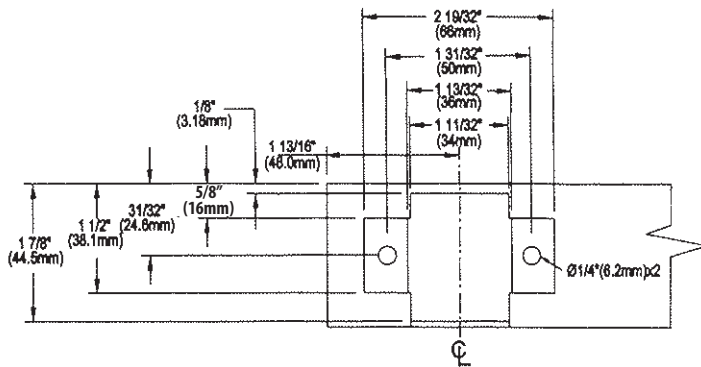

Figure 8-1

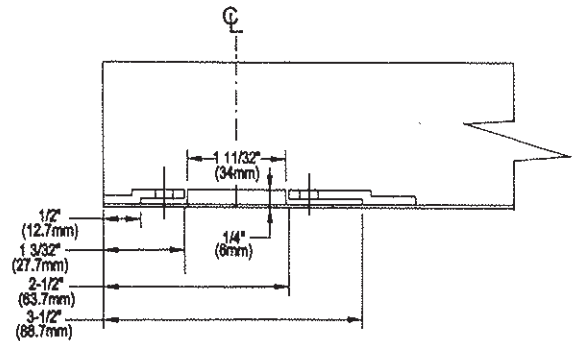

Figure 8-2

2. Install the Top Strike on the strike site (see Figure 8-3), and fasten with supplied screws (see Figure 8-4).

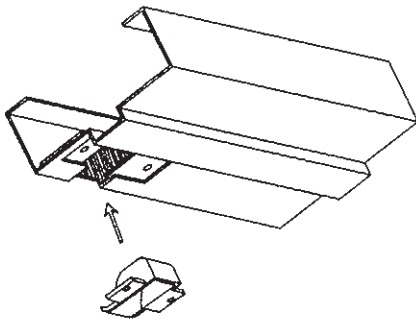

Figure 8-3

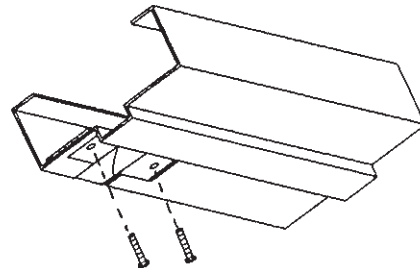
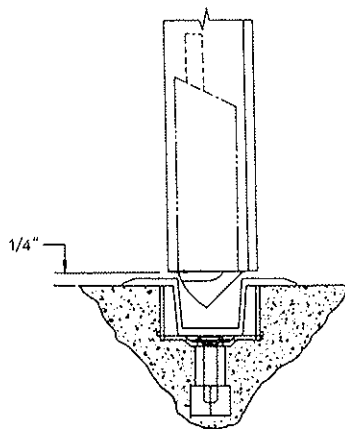
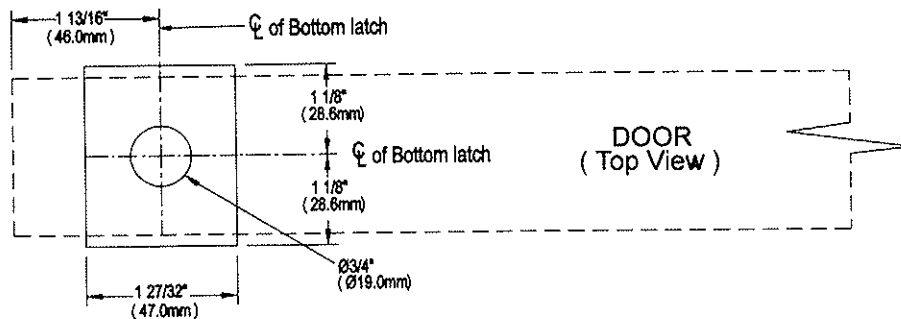

Figure 8-4

9 INSTALL BOTTOM STRIKE

1. Bore the hole on finished floor or threshold as per the figure below.
2. Install bottom strike into the hole.



Strike application

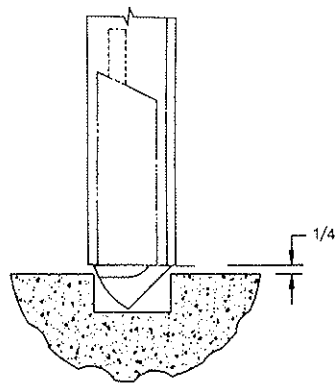

Flat threshold application
(Panic Device Only)

NOTE :

For flat thresholds the clearance must be provided in sill to accommodate full 9/16" (15mm) throw of latch bolt.

10 INSTALL COVERS

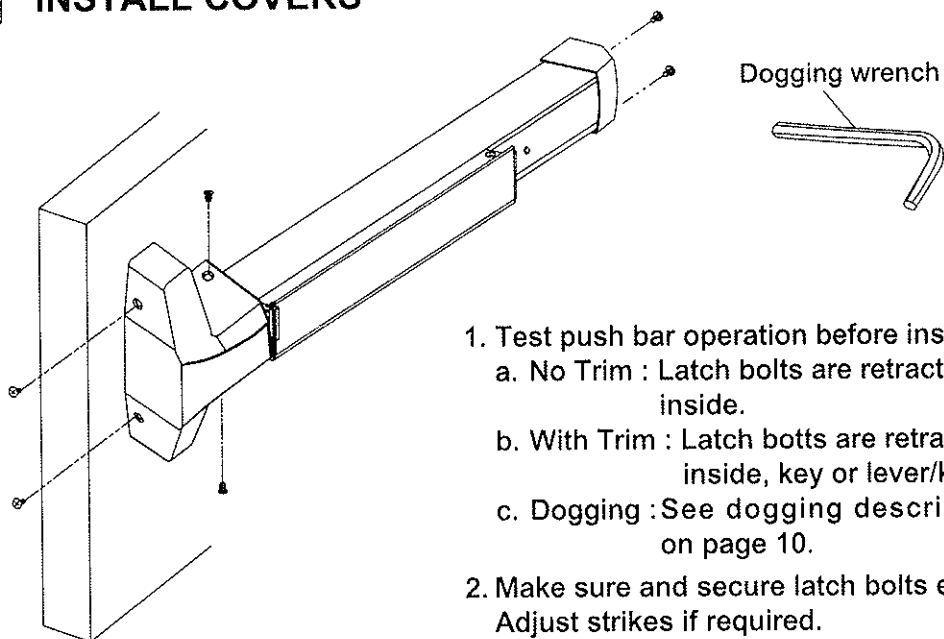

1. Test push bar operation before installing covers.
 - a. No Trim : Latch bolts are retracted by push bar inside.
 - b. With Trim : Latch bolts are retracted by push bar inside, key or lever/knob outside.
 - c. Dogging : See dogging description and chart on page 10.
2. Make sure and secure latch bolts engagement. Adjust strikes if required.
3. Install chassis cover on the chassis assembly.
4. Install end cap.

Door Handing

Use this diagram to determine the hand of door.

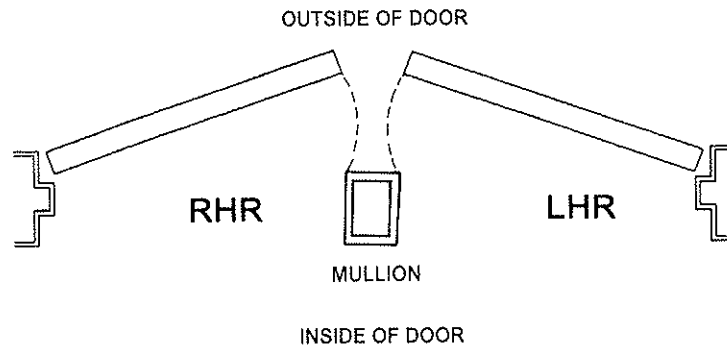

NOTE :

***For extending the life of this device,
dogging device during high traffic
period of the day (Panic device only).***

Dogging :

Insert dogging wrench
and turn clockwise 35°.

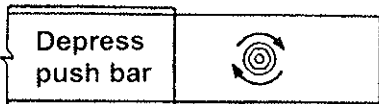

The push bar will remain
pressed and the latches
will keep retracted.

Release dogging :

Insert dogging wrench and
turn counter-clockwise 35°.

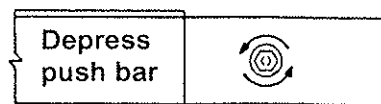

The push bar will return to
up position and the latches
will project to lock the door.

Dogging wrench

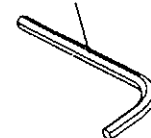

DIMENSIONS FOR CUT-OUT & DRILL HOLES ON DOOR

